

# Off-line transformerless LED driver with power-factor correction and galvanic isolation using high energy density thin-film Metacapacitors

Chengrui Le(1), Daniel Gerber(2), Peter Kinget(1), Seth Sanders(1), Columbia University(1), University of California, Berkeley(2)

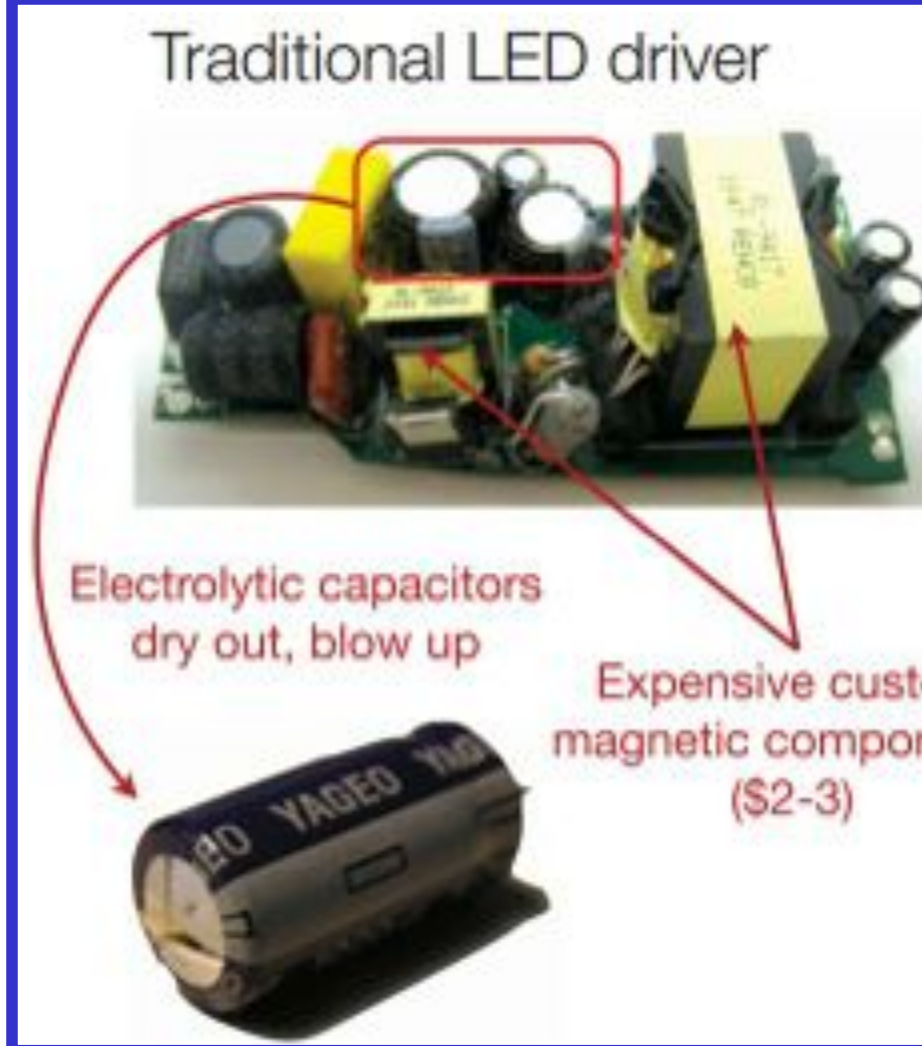

**Traditional LED driver**  
This LED driver design can meet specifications for efficiency and harmonic distortion without the need for bulky transformers and life-time limiting electrolytic capacitors. In addition, there are plans to use a high power density flexible thin-film capacitor technology known as the Metacapacitor.

- Sigma-delta control for multi-level power factor correction input module
- Switched capacitor 4-to-1 DC-DC converter
- Capacitive galvanic isolation via resonant circuit
- Load current regulation
- Dimming capability

## Full Design with PFC and Step-Down Modules

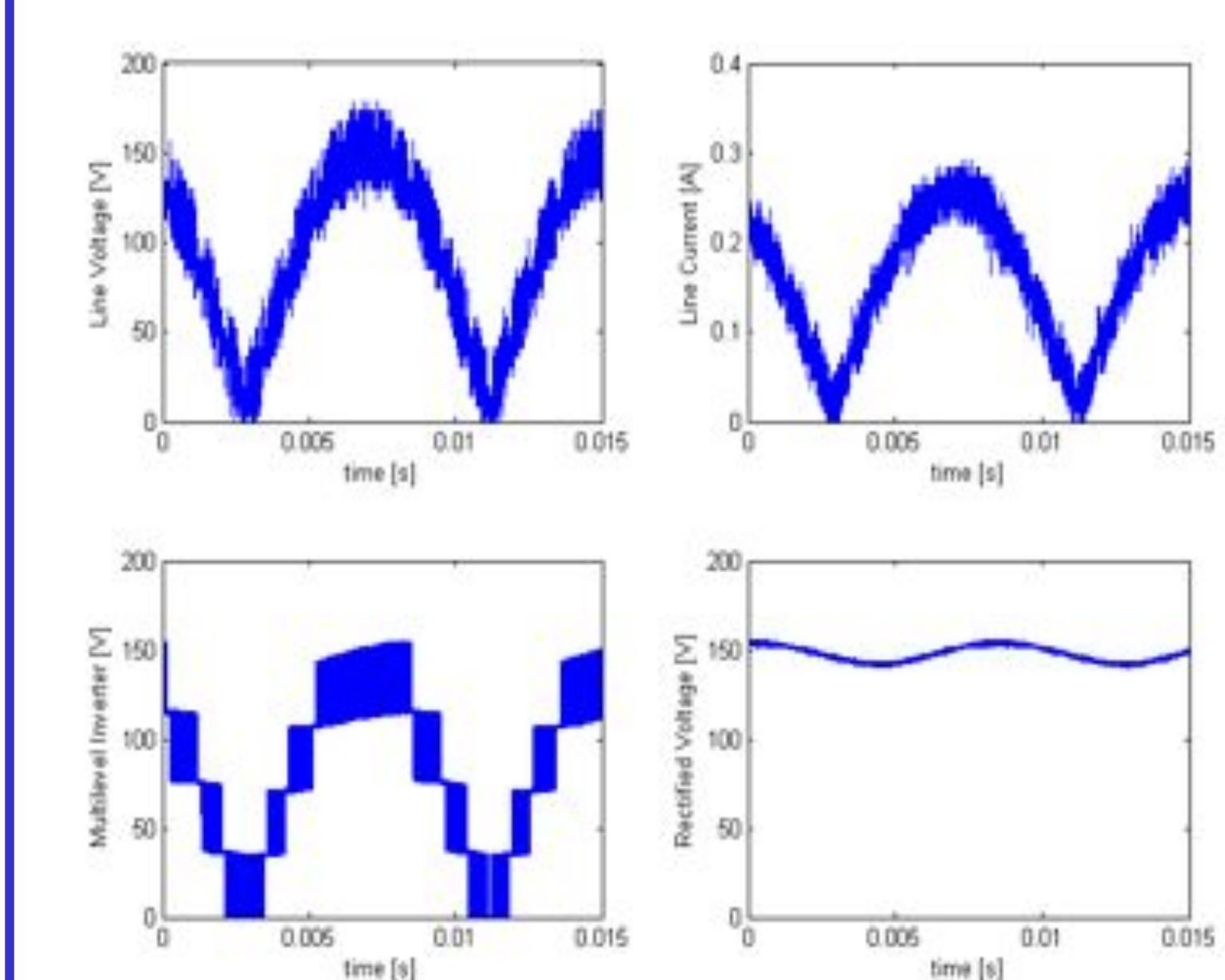
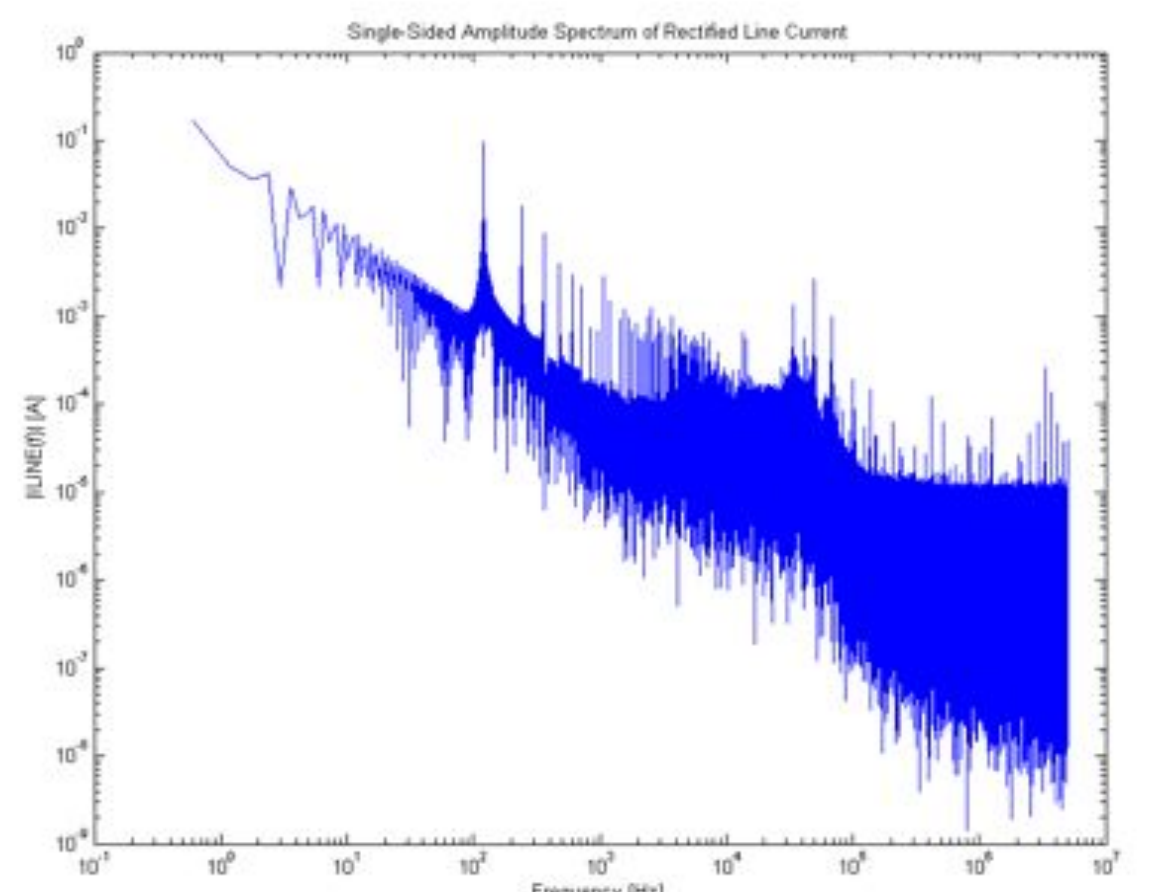
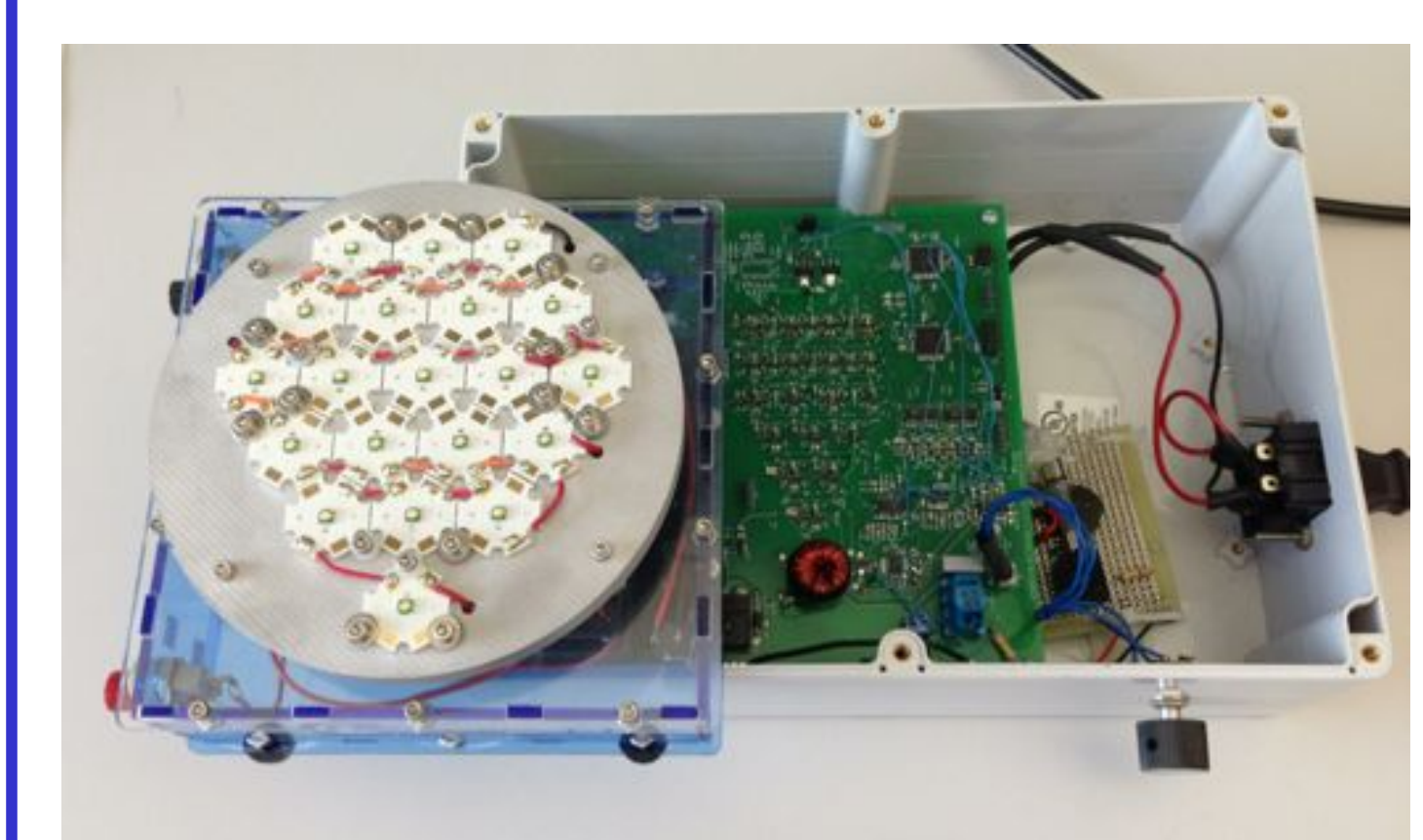
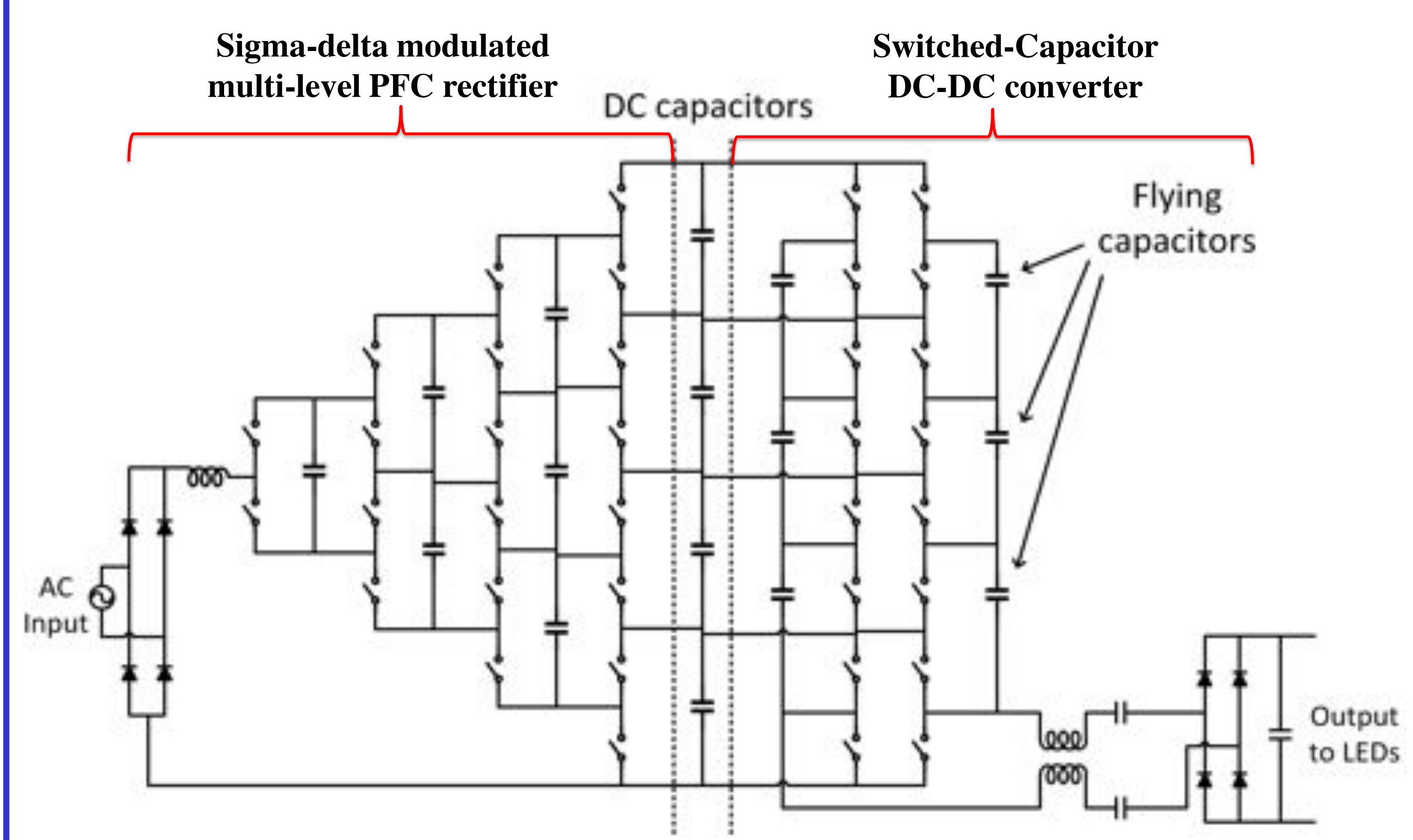

Efficiency (no GD/GD)	90.4%/89.5%
Power Factor	> 0.99
# LEDs	12
Line voltage	74.8 Vrms
Line current	120 mA rms
Line power	8.98 W
LED voltage	35.3 V
LED current	0.23 A
LED power	8.11 W
Gate drive power	87 mW
SD clock	500 kHz
CP clock	262 kHz

## Printable Thin-Film Metacapacitors

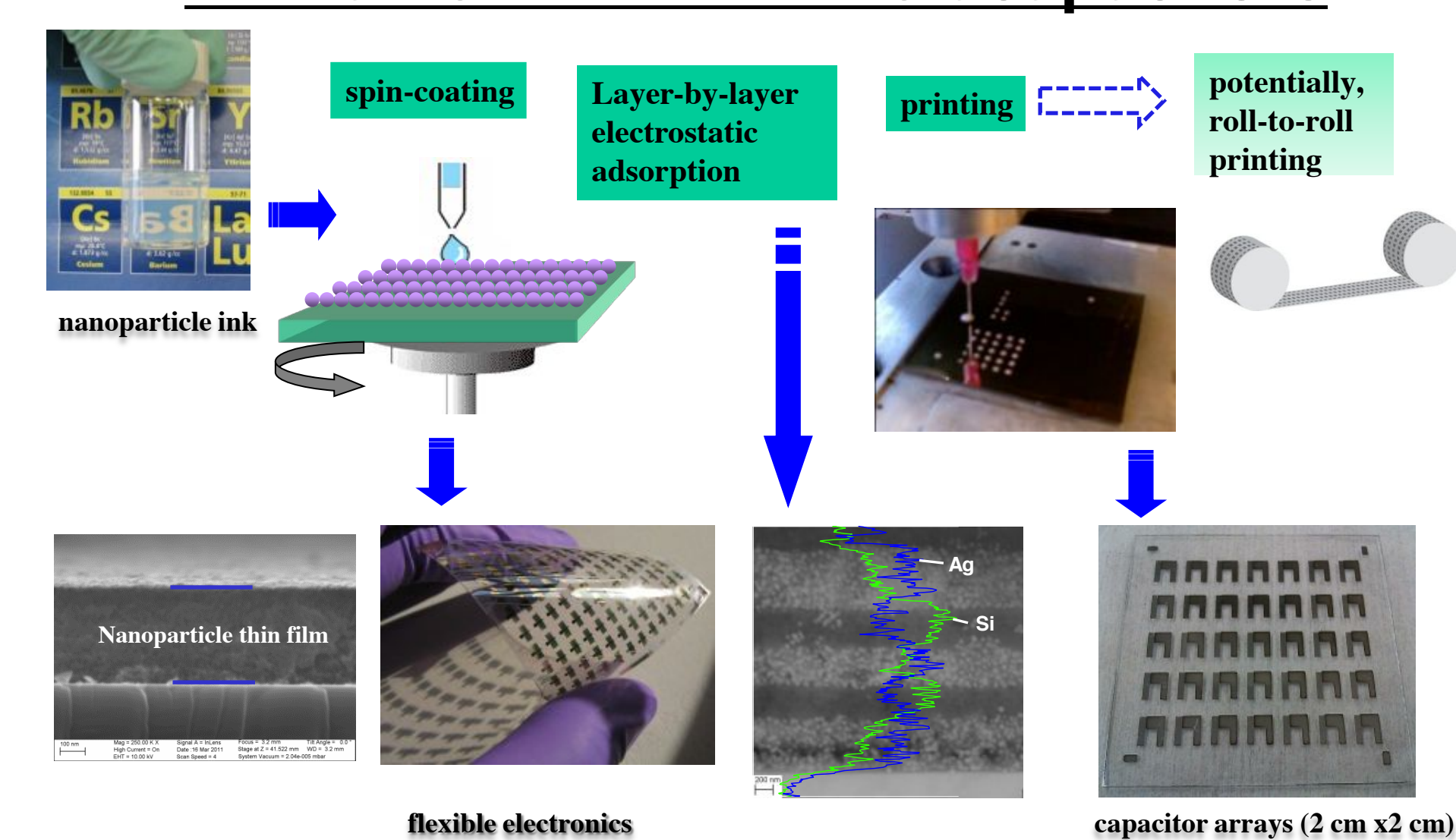

Eli S. Leland<sup>1</sup>, Barry Van Tassel<sup>1</sup>, Paul Chando<sup>1</sup>, Xiaohua Liu<sup>1</sup>, Andrew Byro<sup>1</sup>, Shyuan Yang<sup>2</sup>, Limin Huang<sup>1</sup>, Shuangyi Liu<sup>1</sup>, Olivia Niitsoo<sup>1</sup>, Brian Tull<sup>2</sup>, Alexander Couzis<sup>1</sup>, Dan Steingart<sup>1</sup>, Ioannis Kymissis<sup>2</sup>, Steve O'Brien<sup>1</sup>, 1 - City College of New York, 2 - Columbia University

>Liu, S.; L.; Huang, L.; Li, J.; O'Brien, S., Intrinsic dielectric frequency dependent spectrum of a single domain tetragonal BaTiO<sub>3</sub>, Journal of Applied Physics Issue Number: 112, 2012, 014108, <http://dx.doi.org/10.1063/1.4734004>

>Yang, S.; Tull, B. R.; Pervez, N. K.; Huang, L.; Leland, E. S.; Steigart, D. A.; O'Brien, S.; Kymissis, I. Asymmetric Leakage in (Ba, Sr)TiO<sub>3</sub> Nanoparticle/Parylene-C Composite Capacitors, Journal of Polymer Science B: Polymer Physics, Advance Article, 2012, <http://dx.doi.org/10.1002/polb.23156>

>Liu, S.; Zhang, H.; Lev Sviridov, L.; Huang, L.; Xiaohua Liu, X.; Jacopo Samson, J.; Akins, D. L.; Li, J.; O'Brien, S., Comprehensive Dielectric Performance of Bismuth Acceptor Doped BaTiO<sub>3</sub> Based Nanocrystal Thin Film Capacitors, Journal of Materials Chemistry, Advance Article, 2012, <http://dx.doi.org/10.1039/C2JM34044E>

>Leland, Eli S., Metacapacitors—Next-Generation Power Electronics for LED Lighting and Other Applications, NEMA Electroindustry Magazine, Vol. 17 No. 7 pp. 8-9, July 2012, [http://www.nxtbook.com/ygsreprints/NEMA/g27429\\_nema\\_ei\\_july2012/#10](http://www.nxtbook.com/ygsreprints/NEMA/g27429_nema_ei_july2012/#10)

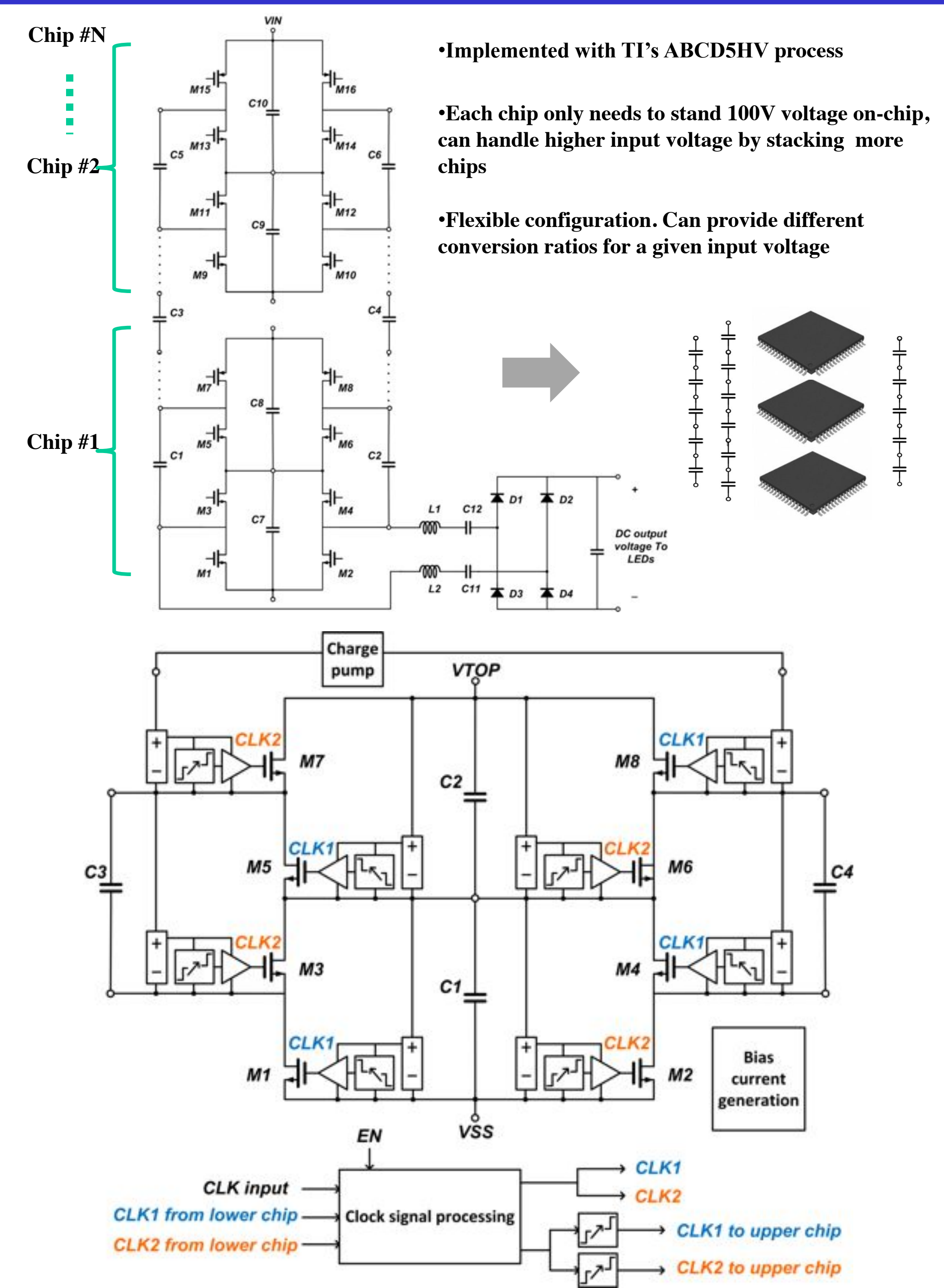

- Implemented with TI's ABCD5HV process
- Each chip only needs to stand 100V voltage on-chip, can handle higher input voltage by stacking more chips
- Flexible configuration. Can provide different conversion ratios for a given input voltage

## DC-DC Step-Down Prototype and IC

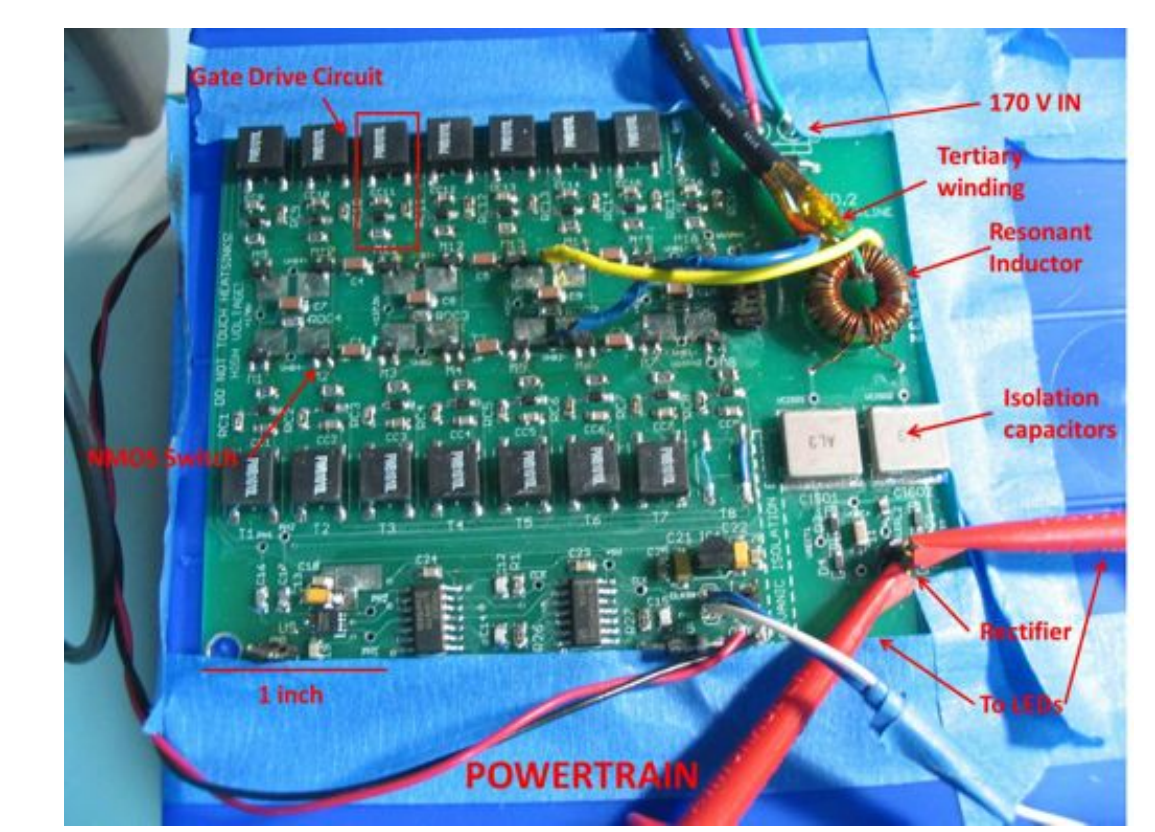

Regulation loop dynamics [10us/div]. Top: Global ENABLE signal. Middle: STARTUP signal. Bottom: Current through isolation capacitors [400mA/div].

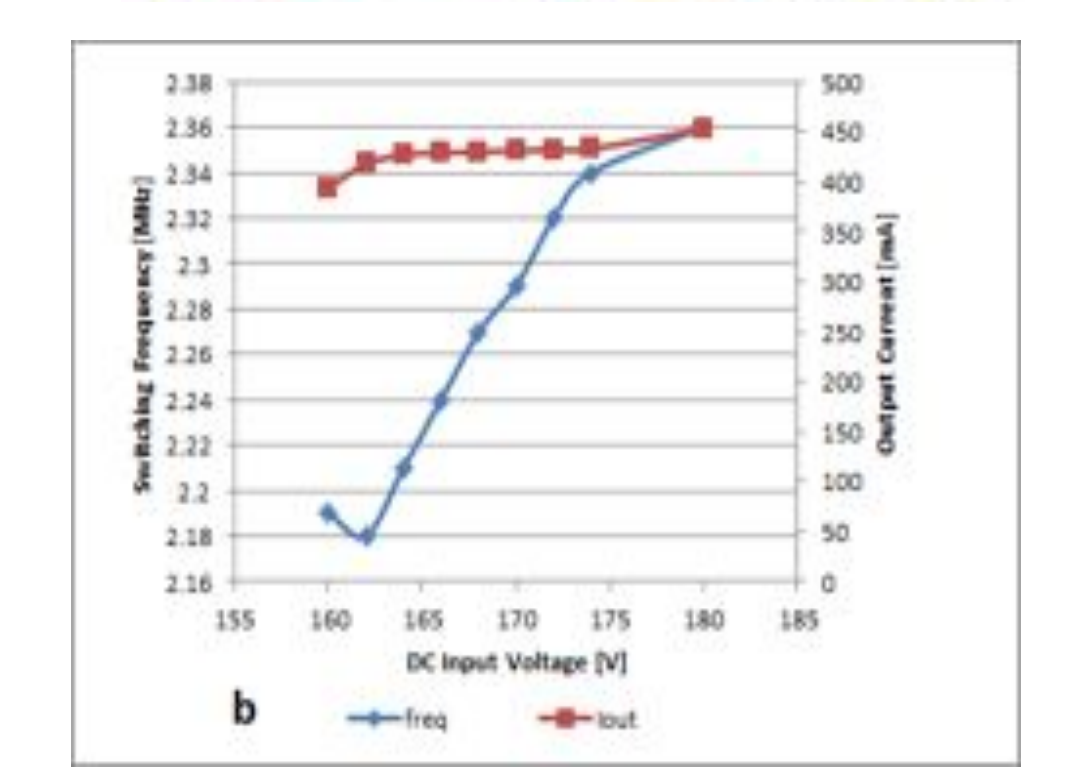
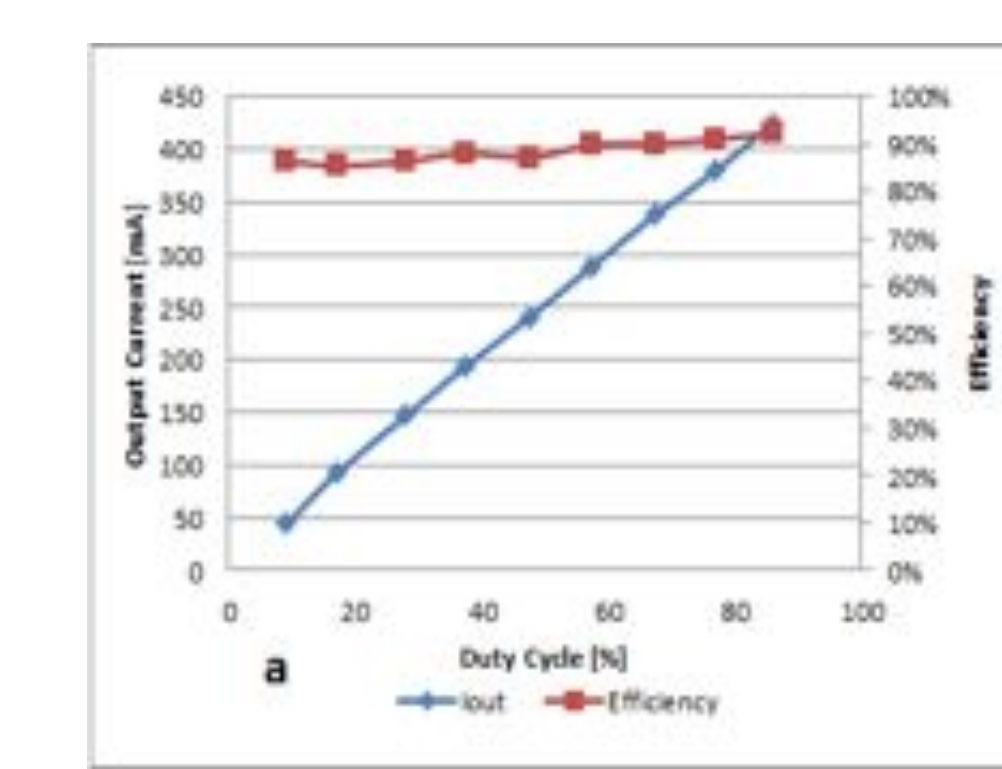

(a) Current regulation and efficiency versus duty cycle  
(b) Switching frequency and current regulation versus input voltage.

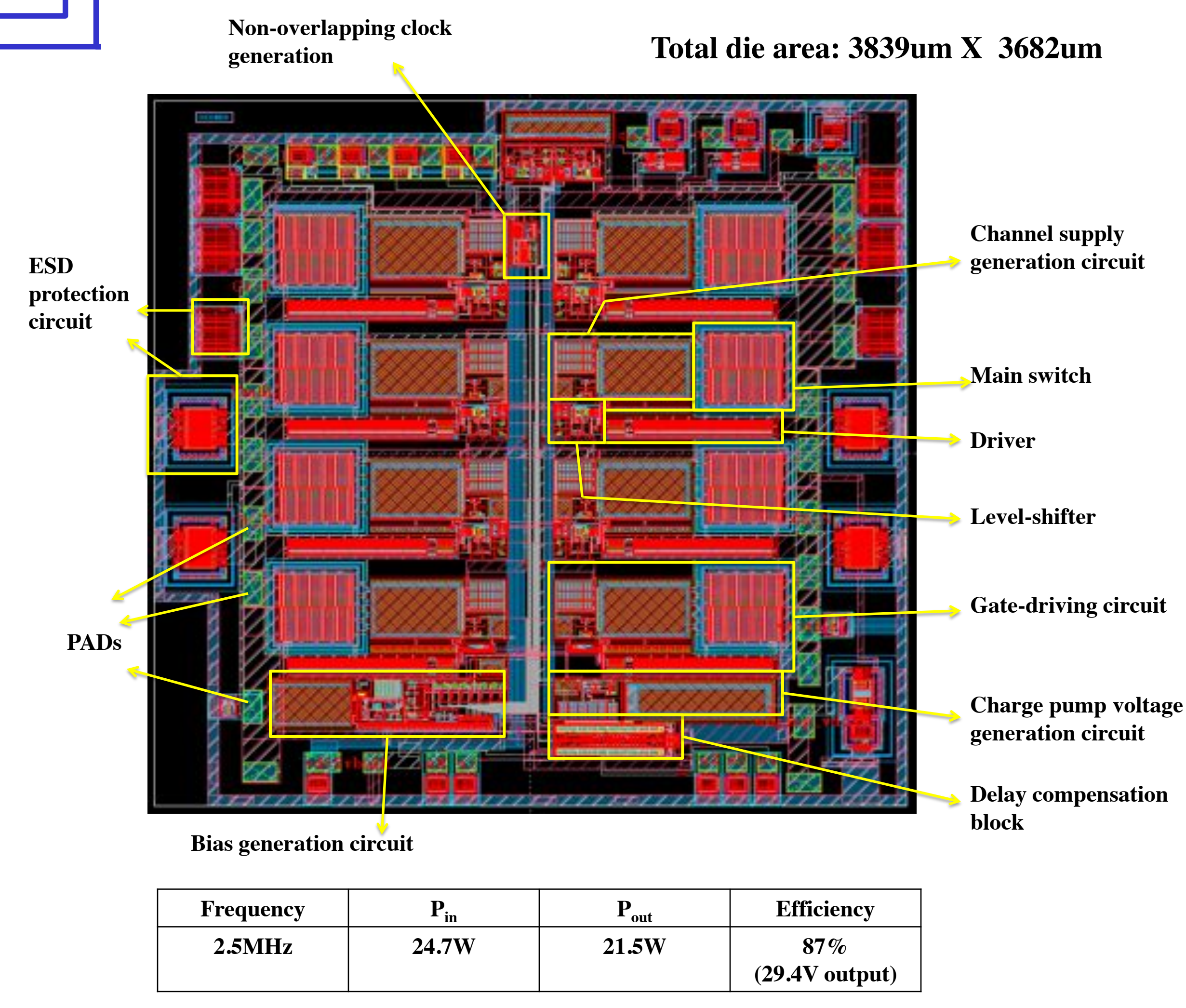

Frequency	P <sub>in</sub>	P <sub>out</sub>	Efficiency
2.5MHz	24.7W	21.5W	87% (29.4V output)

## Acknowledgements :

arpa-e ARPA-E ADEPT Metacapacitors. DE-AR000114. Prior and additional support from NSF, DOE and NYSERDA

TEXAS INSTRUMENTS Texas Instruments Silicon Valley Labs Ali Djabbari, Bijoy Chatterjee, Gianpaolo Lisi, Raj Subramoniam, Glen Wells, Zhenyong Zhang, and Jerry Socci